

United Kingdom  
Mathematics Trust

# Senior Mathematical Challenge

## Questions by Topic: 2002 – 2024 Collection

[www.CasperYC.club](http://www.CasperYC.club)

Last updated: October 27, 2024

Compiled by: Dr Yu (郁博士)

Editors: May, Curtis, Lily

1	3D shapes	1	10 Indices and Surds	64
2	Angles	6	11 Logic	71
3	Averages	14	12 Number Work	76
4	Circles	16	13 Percentages	95
5	Combinations and Probability	24	14 Prime Numbers	98
6	Coordinate Geometry	29	15 Proof	101
7	Equations	40	16 Ratio	102
8	Fractions	50	17 Trigonometry	107
9	Geometry	55		



Comments and suggestions to [DrYuFromShanghai@QQ.com](mailto:DrYuFromShanghai@QQ.com)





# 1 3D shapes

Q1 : 2003–Q23

[www.CasperYC.club/ukmtnav](http://www.CasperYC.club/ukmtnav)

23. The cube,  $XYZTABCD$ , is cut into four pieces by cutting along two planes,  $BCTX$  and  $BDTY$ . What fraction of the volume of the cube is occupied by the piece containing corner  $A$ ?

A  $\frac{3}{8}$       B  $\frac{1}{3}$       C  $\frac{3}{10}$       D  $\frac{5}{18}$       E  $\frac{1}{4}$

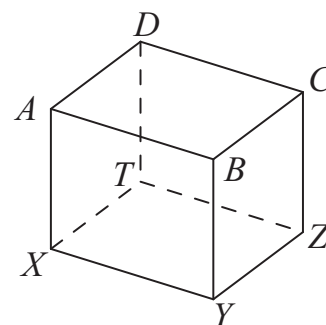

Q2 : 2004–Q12

[www.CasperYC.club/ukmtnav](http://www.CasperYC.club/ukmtnav)

12. One face of a solid polyhedron is a regular hexagon. What is the smallest possible number of edges the polyhedron could have?

A 7      B 9      C 12      D 15      E 18

Q3 : 2005–Q11

[www.CasperYC.club/ukmtnav](http://www.CasperYC.club/ukmtnav)

- A sculpture is made up of 12 wooden cylinders, each of height 2cm. They are glued together as shown. The diameter of the top cylinder is 2cm and each of the other cylinders has a diameter 2cm more than the one immediately above it. The exhibit stands with its base on a marble table. What, in  $\text{cm}^2$ , is the total surface area of the sculpture, excluding the base?

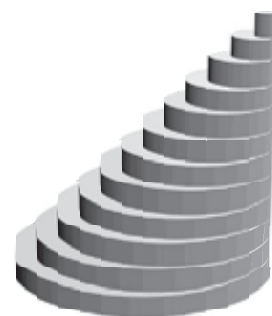

A  $456\pi$       B  $356\pi$       C  $256\pi$       D  $156\pi$       E  $144\pi$

Q4 : 2005–Q18

[www.CasperYC.club/ukmtnav](http://www.CasperYC.club/ukmtnav)

- A cube exactly fits inside a sphere and another sphere exactly fits inside this cube. What is the ratio of the volume of the smaller sphere to the volume of the larger sphere?

A  $1 : 3\sqrt{3}$       B  $1 : 4$       C  $1 : 3$       D  $2 : 3$       E  $1 : 2$



Q5 : 2006–Q24

[www.CasperYC.club/ukmtnav](http://www.CasperYC.club/ukmtnav)

A solid red plastic cube, volume  $1 \text{ cm}^3$ , is painted white on its outside. The cube is cut by a plane passing through the midpoints of various edges, as shown.

What, in  $\text{cm}^2$ , is the *total* red area exposed by the cut?

- A  $\frac{3\sqrt{3}}{2}$     B 2    C  $\frac{9\sqrt{2}}{5}$     D 3    E  $\frac{3(\sqrt{3} + \sqrt{2})}{4}$

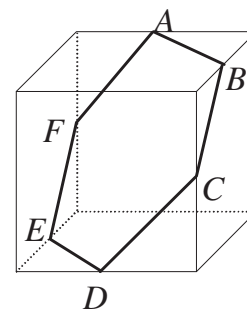

Q6 : 2006–Q7

[www.CasperYC.club/ukmtnav](http://www.CasperYC.club/ukmtnav)

The base of a pyramid has  $n$  edges. What is the difference between the number of edges the pyramid has and the number of faces the pyramid has?

- A  $n - 2$     B  $n - 1$     C  $n$     D  $n + 1$     E  $n + 2$

Q7 : 2007–Q11

[www.CasperYC.club/ukmtnav](http://www.CasperYC.club/ukmtnav)

A  $4 \times 4 \times 4$  cube has three  $2 \times 2 \times 4$  holes drilled symmetrically all the way through, as shown.

What is the surface area of the resulting solid?

- A 192    B 144    C 136    D 120    E 96

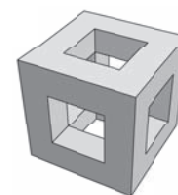

Q8 : 2007–Q24

[www.CasperYC.club/ukmtnav](http://www.CasperYC.club/ukmtnav)

A paperweight is made from a glass cube of side 2 units by first shearing off the eight tetrahedral corners which touch at the midpoints of the edges of the cube. The remaining inner core of the cube is discarded and replaced by a sphere. The eight corner pieces are now stuck onto the sphere so that they have the same positions relative to each other as they did originally. What is the diameter of the sphere?

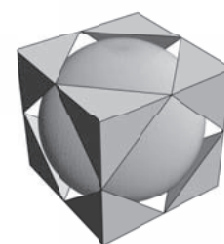

- A  $\sqrt{8} - 1$     B  $\sqrt{8} + 1$     C  $\frac{1}{3}(6 + \sqrt{3})$     D  $\frac{4}{3}\sqrt{3}$     E  $2\sqrt{3}$

Q9 : 2009–Q17

[www.CasperYC.club/ukmtnav](http://www.CasperYC.club/ukmtnav)

A solid cube is divided into two pieces by a single rectangular cut. As a result, the total surface area increases by a fraction  $f$  of the surface area of the original cube. What is the greatest possible value of  $f$ ?

- A  $\frac{1}{3}$     B  $\frac{\sqrt{3}}{4}$     C  $\frac{\sqrt{2}}{3}$     D  $\frac{1}{2}$     E  $\frac{1}{\sqrt{3}}$



Q10 : 2009–Q23

[www.CasperYC.club/ukmtnav](http://www.CasperYC.club/ukmtnav)

The net shown is folded into an icosahedron and the remaining faces are numbered such that at each vertex the numbers 1 to 5 all appear. What number must go on the face with a question mark?

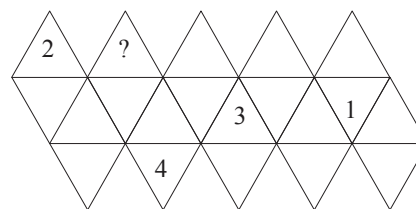

- A 1      B 2      C 3      D 4      E 5

Q11 : 2010–Q18

[www.CasperYC.club/ukmtnav](http://www.CasperYC.club/ukmtnav)

A solid cube of side 2 cm is cut into two triangular prisms by a plane passing through four vertices, as shown. What is the total surface area of these two prisms?

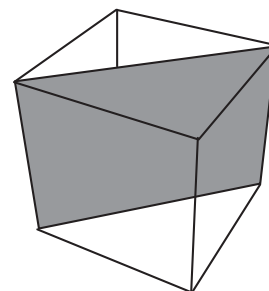

- A  $8(3 + \sqrt{2})$       B  $2(8 + \sqrt{2})$       C  $8(3 + 2\sqrt{2})$   
 D  $16(3 + \sqrt{2})$       E  $8\sqrt{2}$

Q12 : 2010–Q24

[www.CasperYC.club/ukmtnav](http://www.CasperYC.club/ukmtnav)

Three spheres of radius 1 are placed on a horizontal table and inside a vertical hollow cylinder of height 2 units which is just large enough to surround them. What fraction of the internal volume of the cylinder is occupied by the spheres?

- A  $\frac{2}{7 + 4\sqrt{3}}$       B  $\frac{2}{2 + \sqrt{3}}$       C  $\frac{1}{3}$       D  $\frac{3}{2 + \sqrt{3}}$       E  $\frac{6}{7 + 4\sqrt{3}}$

Q13 : 2011–Q25

[www.CasperYC.club/ukmtnav](http://www.CasperYC.club/ukmtnav)

A solid sculpture consists of a  $4 \times 4 \times 4$  cube with a  $3 \times 3 \times 3$  cube sticking out, as shown. Three vertices of the smaller cube lie on edges of the larger cube, the same distance along each.

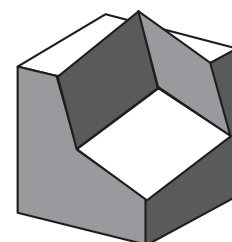

What is the total volume of the sculpture?

- A 79      B 81      C 82      D 84      E 85

Q14 : 2011–Q9

[www.CasperYC.club/ukmtnav](http://www.CasperYC.club/ukmtnav)

Sam has a large collection of  $1 \times 1 \times 1$  cubes, each of which is either red or yellow. Sam makes a  $3 \times 3 \times 3$  block from twenty-seven cubes, so that no cubes of the same colour meet face-to-face.

What is the difference between the largest number of red cubes that Sam can use and the smallest number?

- A 0      B 1      C 2      D 3      E 4



Q15 : 2012–Q13

[www.CasperYC.club/ukmtnav](http://www.CasperYC.club/ukmtnav)

A cube is placed with one face on square 1 in the maze shown, so that it completely covers the square with no overlap. The upper face of the cube is covered in wet paint. The cube is then ‘rolled’ around the maze, rotating about an edge each time, until it reaches square 25. It leaves paint on all of the squares on which the painted face lands, but on no others. The cube is removed on reaching the square 25. What is the sum of the numbers on the squares which are now marked with paint?

5	6	7	8	9
4	19	20	21	10
3	18	25	22	11
2	17	24	23	12
1	16	15	14	13

- A 78                      B 80                      C 82                      D 169                      E 625

Q16 : 2014–Q13

[www.CasperYC.club/ukmtnav](http://www.CasperYC.club/ukmtnav)

Each of the five nets P, Q, R, S and T is made from six squares. Both sides of each square have the same colour. Net P is folded to form a cube.

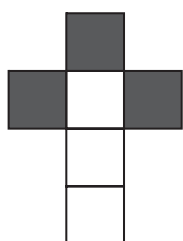

P

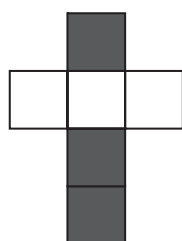

Q

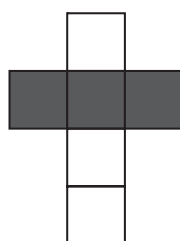

R

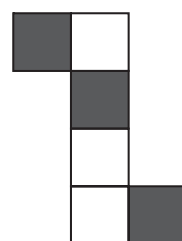

S

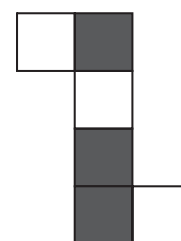

T

How many of the nets Q, R, S and T can be folded to produce a cube that looks the same as that produced by P?

- A 0                      B 1                      C 2                      D 3                      E 4

Q17 : 2015–Q15

[www.CasperYC.club/ukmtnav](http://www.CasperYC.club/ukmtnav)

Two vases are cylindrical in shape. The larger vase has diameter 20 cm. The smaller vase has diameter 10 cm and height 16 cm. The larger vase is partially filled with water. Then the empty smaller vase, with the open end at the top, is slowly pushed down into the water, which flows over its rim. When the smaller vase is pushed right down, it is half full of water.

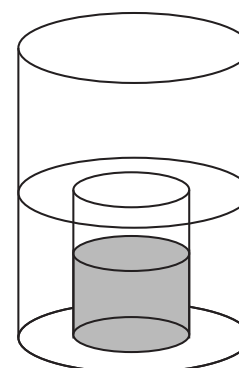

What was the original depth of the water in the larger vase?

- A 10 cm                      B 12 cm                      C 14 cm                      D 16 cm                      E 18 cm



Q18 : 2016–Q23

[www.CasperYC.club/ukmtnav](http://www.CasperYC.club/ukmtnav)

A cuboid has sides of lengths 22, 2 and 10. It is contained within a sphere of the smallest possible radius. What is the side-length of the largest cube that will fit inside the same sphere?

- A 10                      B 11                      C 12                      D 13                      E 14

Q19 : 2018–Q12

[www.CasperYC.club/ukmtnav](http://www.CasperYC.club/ukmtnav)

12. A regular tetrahedron is a polyhedron with four faces, each of which is an equilateral triangle, as shown. A solid regular tetrahedron is cut into two pieces by a single plane cut.

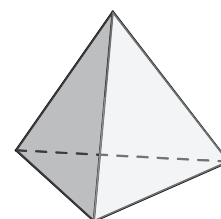

Which of the following could *not* be the shape of the section formed by the cut?

- A a pentagon                      B a square  
C a rectangle that is not a square                      D a trapezium  
E a triangle that is not equilateral

Q20 : 2018–Q24

[www.CasperYC.club/ukmtnav](http://www.CasperYC.club/ukmtnav)

24. The diagram shows a circle with centre  $O$  which lies in a horizontal plane. The diameter  $AB$  has length 4. Point  $P$  lies vertically above  $O$  and  $PO = 2\sqrt{2}$ . Point  $C$  lies on the semicircular arc  $AB$  such that the ratio of the lengths of the arcs  $AC$  and  $CB$  is 2 : 1.

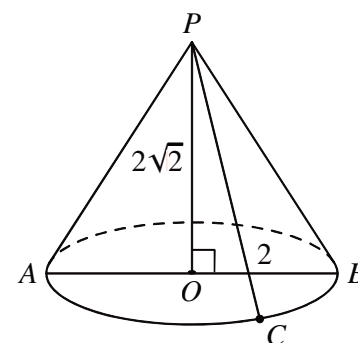

What is the shortest distance from  $A$  to  $PC$ ?

- A  $\sqrt{2}$                       B  $\sqrt{3}$                       C 2                      D  $2\sqrt{2}$                       E 3

Q21 : 2019–Q23

[www.CasperYC.club/ukmtnav](http://www.CasperYC.club/ukmtnav)

23. The edge-length of the solid cube shown is 2. A single plane cut goes through the points  $Y$ ,  $T$ ,  $V$  and  $W$  which are midpoints of the edges of the cube, as shown.

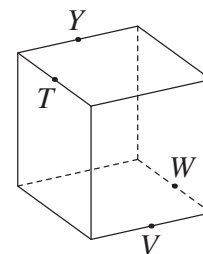

What is the area of the cross-section?

- A  $\sqrt{3}$                       B  $3\sqrt{3}$                       C 6                      D  $6\sqrt{2}$                       E 8

Q22 : 2020–Q3

[www.CasperYC.club/ukmtnav](http://www.CasperYC.club/ukmtnav)

3. A shape is made from five unit cubes, as shown.

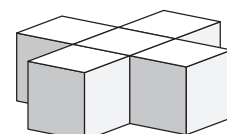

What is the surface area of the shape?

- A 22                      B 24                      C 26                      D 28                      E 30



## 2 Angles

Q23 : 2003–Q20

[www.CasperYC.club/ukmtnav](http://www.CasperYC.club/ukmtnav)

20. All six vertices of hexagon  $UVWXYZ$  lie on the circumference of a circle;  $\angle ZUV = 88^\circ$  and  $\angle XYZ = 158^\circ$ . What is the size of  $\angle VWX$ ?

- A  $92^\circ$     B  $114^\circ$     C  $120^\circ$     D  $132^\circ$     E it is impossible to determine

Q24 : 2004–Q14

[www.CasperYC.club/ukmtnav](http://www.CasperYC.club/ukmtnav)

14.  $L$ ,  $M$  and  $N$  are midpoints of the sides of a skeleton cube, as shown. What is the value of angle  $LMN$ ?

- A  $90^\circ$     B  $105^\circ$     C  $120^\circ$     D  $135^\circ$     E  $150^\circ$

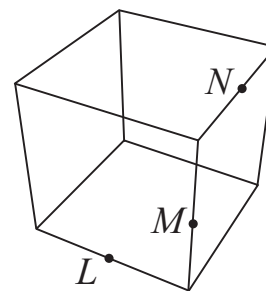

Q25 : 2004–Q18

[www.CasperYC.club/ukmtnav](http://www.CasperYC.club/ukmtnav)

18. In the diagram, the line  $PQ$  is a tangent at  $N$  to the circle through points  $L$ ,  $M$  and  $N$ . The lengths  $LM$  and  $LN$  are equal. The line  $LM$  produced meets the tangent  $PQ$  at the point  $R$ .

If  $\angle PNL = \theta^\circ$ , what is the value, in degrees, of  $\angle LRP$ ?

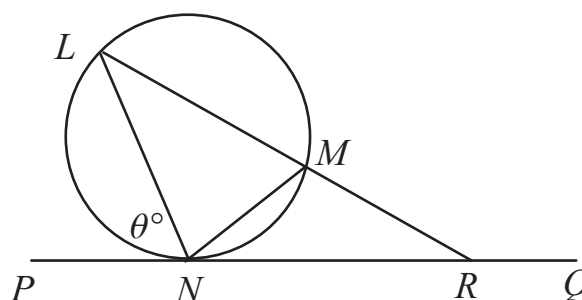

- A  $3\theta - 180$     B  $180 - 2\theta$     C  $180 - \theta$     D  $90 - \frac{1}{2}\theta$     E  $\theta$

Q26 : 2005–Q13

[www.CasperYC.club/ukmtnav](http://www.CasperYC.club/ukmtnav)

In the figure shown, what is the sum of the interior angles at  $A$ ,  $B$ ,  $C$ ,  $D$ ,  $E$ ?

- A  $90^\circ$     B  $135^\circ$     C  $150^\circ$     D  $180^\circ$   
E more information required.

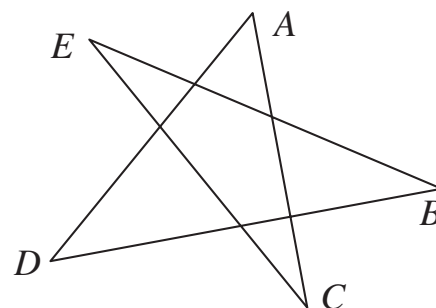

Q27 : 2005–Q3

[www.CasperYC.club/ukmtnav](http://www.CasperYC.club/ukmtnav)

What is the mean of the five numbers  $1^5$ ,  $2^4$ ,  $3^3$ ,  $4^2$  and  $5^1$ ?

- A 6.2    B 11.4    C 12.2    D 13    E 13.8



Q28 : 2006-Q21

[www.CasperYC.club/ukmtnav](http://www.CasperYC.club/ukmtnav)

A toy pool table is 6 feet long and 3 feet wide. It has pockets at each of the four corners  $P$ ,  $Q$ ,  $R$  and  $S$ . When a ball hits a side of the table, it bounces off the side at the same angle as it hit that side. A ball, initially 1 foot to the left of pocket  $P$ , is hit from the side  $SP$  towards the side  $PQ$  as shown.

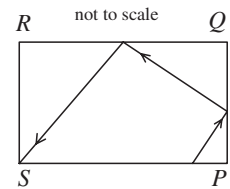

How many feet from  $P$  does the ball hit side  $PQ$  if it lands in pocket  $S$  after two bounces?

- A 1                      B  $\frac{6}{7}$                       C  $\frac{3}{4}$                       D  $\frac{2}{3}$                       E  $\frac{3}{5}$

Q29 : 2006-Q3

[www.CasperYC.club/ukmtnav](http://www.CasperYC.club/ukmtnav)

The diagram shows overlapping squares.

What is the value of  $x + y$ ?

- A 270                      B 300                      C 330  
D 360                      E more information needed

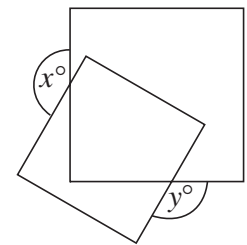

Q30 : 2007-Q17

[www.CasperYC.club/ukmtnav](http://www.CasperYC.club/ukmtnav)

The two triangles have equal areas and the four marked lengths are equal.

What is the value of  $x$ ?

- A 30                      B 45                      C 60                      D 75                      E more information needed

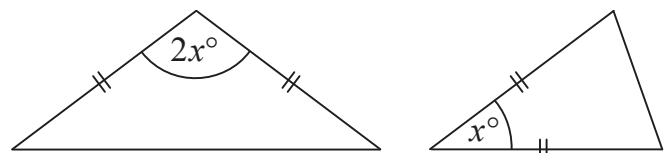

Q31 : 2007-Q19

[www.CasperYC.club/ukmtnav](http://www.CasperYC.club/ukmtnav)

The largest circle which it is possible to draw inside triangle  $PQR$  touches the triangle at  $S$ ,  $T$  and  $U$ , as shown in the diagram.

The size of  $\angle STU = 55^\circ$ . What is the size of  $\angle PQR$ ?

- A  $55^\circ$                       B  $60^\circ$                       C  $65^\circ$                       D  $70^\circ$                       E  $75^\circ$

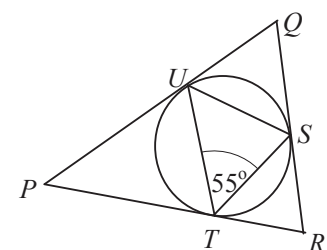

Q32 : 2007–Q4

[www.CasperYC.club/ukmtnav](http://www.CasperYC.club/ukmtnav)

The diagram shows square  $PQRS$  and regular hexagon  $PQTUVW$ .

What is the size of  $\angle PSW$ ?

- A  $10^\circ$       B  $12^\circ$       C  $15^\circ$       D  $24^\circ$       E  $30^\circ$

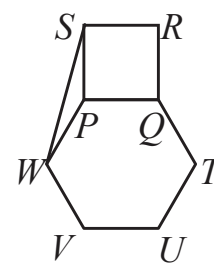

Q33 : 2008–Q8

[www.CasperYC.club/ukmtnav](http://www.CasperYC.club/ukmtnav)

In the figure shown,  $AB = AF$  and  $ABC$ ,  $AFD$ ,  $BFE$  and  $CDE$  are all straight lines.

Which of the following expressions gives  $z$  in terms of  $x$  and  $y$ ?

- A  $\frac{y-x}{2}$       B  $y - \frac{x}{2}$       C  $\frac{y-x}{3}$       D  $y - \frac{x}{3}$       E  $y - x$

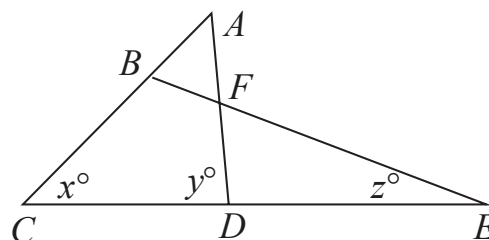

Q34 : 2009–Q14

[www.CasperYC.club/ukmtnav](http://www.CasperYC.club/ukmtnav)

$P, Q, R, S, T$  are vertices of a regular polygon. The sides  $PQ$  and  $TS$  are produced to meet at  $X$ , as shown in the diagram, and  $\angle QXS = 140^\circ$ . How many sides does the polygon have?

- A 9      B 18      C 24      D 27      E 40

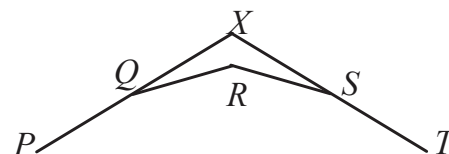

Q35 : 2009–Q20

[www.CasperYC.club/ukmtnav](http://www.CasperYC.club/ukmtnav)

A point  $P$  is chosen at random inside a square  $QRST$ . What is the probability that  $\angle RPQ$  is acute?

- A  $\frac{3}{4}$       B  $\sqrt{2}-1$       C  $\frac{1}{2}$       D  $\frac{\pi}{4}$       E  $1 - \frac{\pi}{8}$

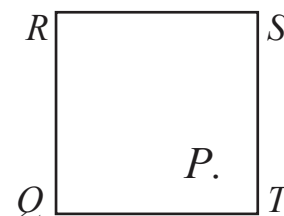

Q36 : 2010–Q3

[www.CasperYC.club/ukmtnav](http://www.CasperYC.club/ukmtnav)

The diagram shows an equilateral triangle touching two straight lines. What is the sum of the four marked angles?

- A  $120^\circ$       B  $180^\circ$       C  $240^\circ$       D  $300^\circ$       E  $360^\circ$

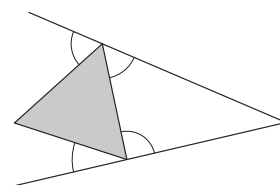

Q37 : 2011-Q19

[www.CasperYC.club/ukmtnav](http://www.CasperYC.club/ukmtnav)

The diagram shows a small regular octagram (an eight-sided star) surrounded by eight squares (dark grey) and eight kites (light grey) to make a large regular octagram. Each square has area 1.

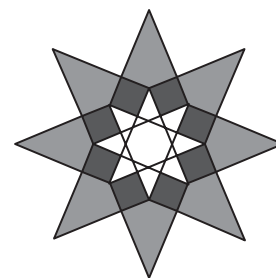

What is the area of one of the light grey kites?

- A 2      B  $\sqrt{2} + 1$       C  $\frac{21}{8}$       D  $4\sqrt{2} - 3$       E  $\frac{11}{4}$

Q38 : 2011-Q22

[www.CasperYC.club/ukmtnav](http://www.CasperYC.club/ukmtnav)

In the diagram,  $\angle ABE = 10^\circ$ ;  $\angle EBC = 70^\circ$ ;  $\angle ACD = 50^\circ$ ;  $\angle DCB = 20^\circ$ ;  $\angle DEF = \alpha$ .

Which of the following is equal to  $\tan \alpha$ ?

- A  $\frac{\tan 10^\circ \tan 20^\circ}{\tan 50^\circ}$       B  $\frac{\tan 10^\circ \tan 20^\circ}{\tan 70^\circ}$       C  $\frac{\tan 10^\circ \tan 50^\circ}{\tan 70^\circ}$   
 D  $\frac{\tan 20^\circ \tan 50^\circ}{\tan 70^\circ}$       E  $\frac{\tan 10^\circ \tan 70^\circ}{\tan 50^\circ}$

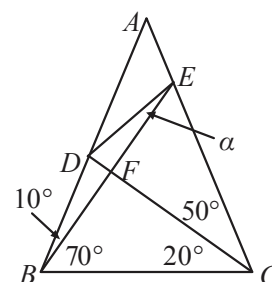

Q39 : 2011-Q5

[www.CasperYC.club/ukmtnav](http://www.CasperYC.club/ukmtnav)

The diagram shows a regular hexagon inside a rectangle.

What is the sum of the four marked angles?

- A  $90^\circ$       B  $120^\circ$       C  $150^\circ$       D  $180^\circ$       E  $210^\circ$

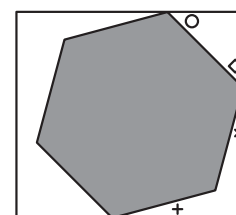

Q40 : 2012-Q2

[www.CasperYC.club/ukmtnav](http://www.CasperYC.club/ukmtnav)

The diagram shows an equilateral triangle, a square and a regular pentagon which all share a common vertex. What is the value of  $\theta$ ?

- A 98      B 102      C 106      D 110      E 112

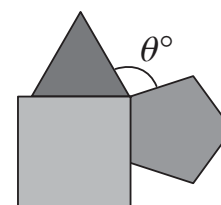

Q41 : 2013-Q17

[www.CasperYC.club/ukmtnav](http://www.CasperYC.club/ukmtnav)

The equilateral triangle  $PQR$  has side-length 1. The lines  $PT$  and  $PU$  trisect the angle  $RPQ$ , the lines  $RS$  and  $RT$  trisect the angle  $QRP$  and the lines  $QS$  and  $QU$  trisect the angle  $PQR$ .

What is the side-length of the equilateral triangle  $STU$ ?

- A  $\frac{\cos 80^\circ}{\cos 20^\circ}$       B  $\frac{1}{3} \cos 20^\circ$       C  $\cos^2 20^\circ$   
 D  $\frac{1}{6}$       E  $\cos 20^\circ \cos 80^\circ$

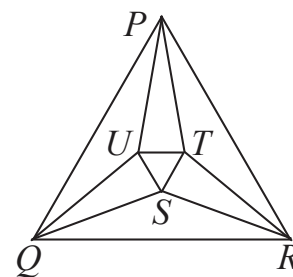

Q42 : 2013-Q24

[www.CasperYC.club/ukmtnav](http://www.CasperYC.club/ukmtnav)

The diagram shows two straight lines  $PR$  and  $QS$  crossing at  $O$ .

What is the value of  $x$ ?

- A  $7\sqrt{2}$       B  $2\sqrt{29}$       C  $14\sqrt{2}$       D  $7(1+\sqrt{13})$       E  $9\sqrt{2}$

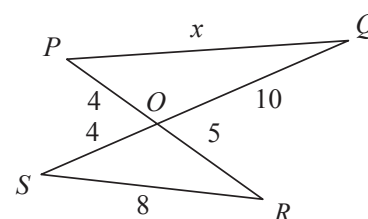

Q43 : 2014-Q25

[www.CasperYC.club/ukmtnav](http://www.CasperYC.club/ukmtnav)

Figure 1 shows a tile in the form of a trapezium, where  $\alpha = 83\frac{1}{3}^\circ$ . Several copies of the tile are placed together to form a symmetrical pattern, part of which is shown in Figure 2. The outer border of the complete pattern is a regular ‘star polygon’. Figure 3 shows an example of a regular ‘star polygon’.

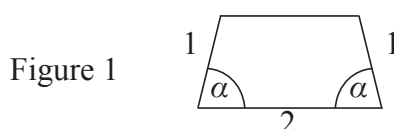

How many tiles are there in the complete pattern?

- A 48      B 54      C 60      D 66      E 72

Q44 : 2015-Q12

[www.CasperYC.club/ukmtnav](http://www.CasperYC.club/ukmtnav)

A circle touches the sides of triangle  $PQR$  at the points  $S$ ,  $T$  and  $U$  as shown. Also  $\angle PQR = \alpha^\circ$ ,  $\angle PRQ = \beta^\circ$  and  $\angle TSU = \gamma^\circ$ . Which of the following gives  $\gamma$  in terms of  $\alpha$  and  $\beta$ ?

- A  $\frac{1}{2}(\alpha + \beta)$       B  $180 - \frac{1}{2}(\alpha + \beta)$   
 C  $180 - (\alpha + \beta)$       D  $\alpha + \beta$   
 E  $\frac{1}{3}(\alpha + \beta)$

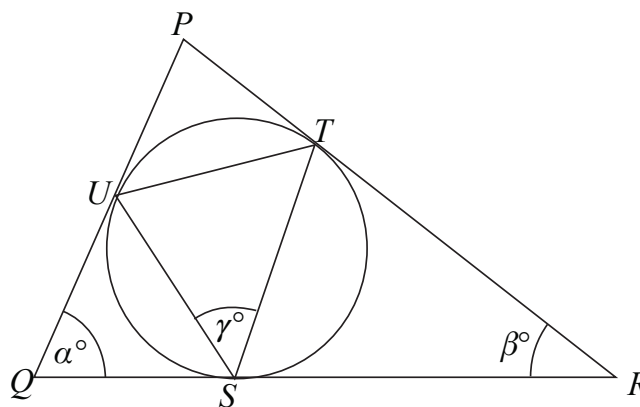

Q45 : 2016-Q15

[www.CasperYC.club/ukmtnav](http://www.CasperYC.club/ukmtnav)

The diagram shows three rectangles and three straight lines.

What is the value of  $p + q + r$ ?

- A 135      B 180      C 210  
D 225      E 270

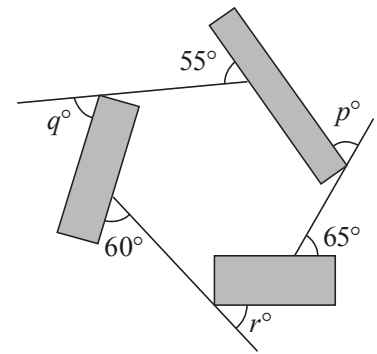

Q46 : 2016-Q4

[www.CasperYC.club/ukmtnav](http://www.CasperYC.club/ukmtnav)

Alex draws a scalene triangle. One of the angles is  $80^\circ$ .

Which of the following could be the difference between the other two angles in Alex's triangle?

- A  $0^\circ$       B  $60^\circ$       C  $80^\circ$       D  $100^\circ$       E  $120^\circ$

Q47 : 2017-Q12

[www.CasperYC.club/ukmtnav](http://www.CasperYC.club/ukmtnav)

The diagram shows a square and a regular decagon that share an edge. One side of the square is extended to meet an extended side of the decagon.

What is the value of  $x$ ?

- A 15      B 18      C 21      D 24      E 27

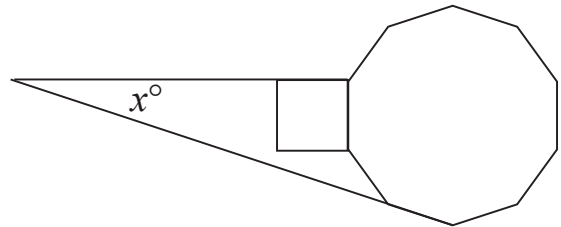

Q48 : 2017-Q14

[www.CasperYC.club/ukmtnav](http://www.CasperYC.club/ukmtnav)

In the diagram, all the angles marked  $\bullet$  are equal in size to the angle marked  $x^\circ$ .

What is the value of  $x$ ?

- A 100      B 105      C 110      D 115      E 120

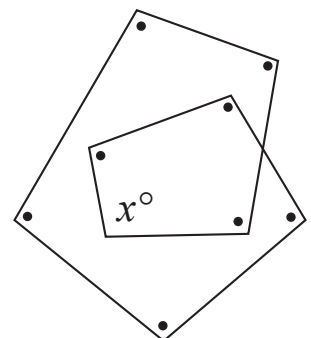

Q49 : 2017–Q22

[www.CasperYC.club/ukmtnav](http://www.CasperYC.club/ukmtnav)

The diagram shows a regular octagon and a square formed by drawing four diagonals of the octagon. The edges of the square have length 1.

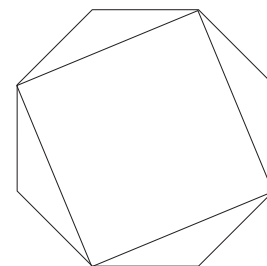

What is the area of the octagon?

- A  $\frac{\sqrt{6}}{2}$       B  $\frac{4}{3}$       C  $\frac{7}{5}$       D  $\sqrt{2}$       E  $\frac{3}{2}$

Q50 : 2018–Q18

[www.CasperYC.club/ukmtnav](http://www.CasperYC.club/ukmtnav)

18.  $P$ ,  $Q$  and  $R$  are the three angles of a triangle, when each has been rounded to the nearest degree.

Which of the following is the complete list of possible values of  $P + Q + R$ ?

- A  $179^\circ, 180^\circ$  or  $181^\circ$       B  $180^\circ, 181^\circ$  or  $182^\circ$       C  $178^\circ, 179^\circ$  or  $180^\circ$       D  $180^\circ$   
E  $178^\circ, 179^\circ, 180^\circ, 181^\circ$  or  $182^\circ$

Q51 : 2018–Q19

[www.CasperYC.club/ukmtnav](http://www.CasperYC.club/ukmtnav)

19. How many pairs of numbers  $(m, n)$  are there such that the following statement is true?

‘A regular  $m$ -sided polygon has an exterior angle of size  $n^\circ$  and a regular  $n$ -sided polygon has an exterior angle of size  $m^\circ$ .’

- A 24      B 22      C 20      D 18      E 16

Q52 : 2019–Q20

[www.CasperYC.club/ukmtnav](http://www.CasperYC.club/ukmtnav)

20. The "heart" shown in the diagram is formed from an equilateral triangle  $ABC$  and two congruent semicircles on  $AB$ . The two semicircles meet at the point  $P$ . The point  $O$  is the centre of one of the semicircles. On the semicircle with centre  $O$ , lies a point  $X$ . The lines  $XO$  and  $XP$  are extended to meet  $AC$  at  $Y$  and  $Z$  respectively. The lines  $XY$  and  $XZ$  are of equal length.

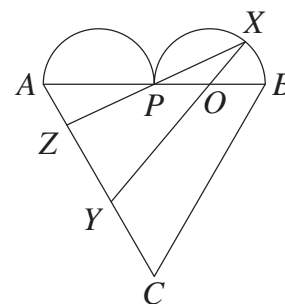

What is  $\angle ZXY$ ?

- A  $20^\circ$       B  $25^\circ$       C  $30^\circ$       D  $40^\circ$       E  $45^\circ$

Q53 : 2020–Q25

[www.CasperYC.club/ukmtnav](http://www.CasperYC.club/ukmtnav)

25. A regular  $m$ -gon, a regular  $n$ -gon and a regular  $p$ -gon share a vertex and pairwise share edges, as shown in the diagram.

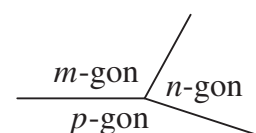

What is the largest possible value of  $p$ ?

- A 6      B 20      C 42      D 50      E 100



Q54 : 2021–Q10

[www.CasperYC.club/ukmtnav](http://www.CasperYC.club/ukmtnav)

10. In a survey, people were asked to name their favourite fruit pie. The pie chart shows the outcome. The angles shown are exact with no rounding.

What is the smallest number of people who could have been surveyed?

- A 45      B 60      C 80      D 90      E 180

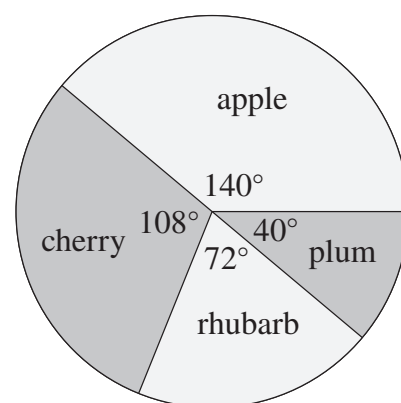

Q55 : 2021–Q22

[www.CasperYC.club/ukmtnav](http://www.CasperYC.club/ukmtnav)

22. A triangle with interior angles  $60^\circ$ ,  $45^\circ$  and  $75^\circ$  is inscribed in a circle of radius 2.

What is the area of the triangle?

- A  $2\sqrt{3}$       B 4      C  $6 + \sqrt{3}$       D  $6\sqrt{3}$       E  $3 + \sqrt{3}$

Q56 : 2021–Q3

[www.CasperYC.club/ukmtnav](http://www.CasperYC.club/ukmtnav)

3. The diagram shows two congruent regular pentagons and a triangle. The angles marked  $x^\circ$  are equal.

What is the value of  $x$ ?

- A 24      B 30      C 36      D 40      E 45

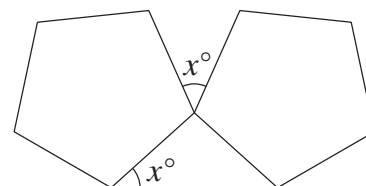

Q57 : 2023–Q13

[www.CasperYC.club/ukmtnav](http://www.CasperYC.club/ukmtnav)

$PQRST$  is a regular pentagon. The point  $U$  lies on  $ST$  such that  $\angle QPU$  is a right angle.

What is the ratio of the interior angles in triangle  $PUT$ ?

- A 1 : 3 : 6      B 1 : 2 : 4      C 2 : 3 : 4      D 1 : 4 : 8      E 1 : 3 : 5

Q58 : 2024–Q4

[www.CasperYC.club/ukmtnav](http://www.CasperYC.club/ukmtnav)

The sizes of the three angles in a triangle, in degrees, are  $x$ ,  $7x$  and  $x^2$ .

What is the size of the largest angle?

- A  $10^\circ$       B  $18^\circ$       C  $100^\circ$       D  $120^\circ$       E  $121^\circ$



### 3 Averages

Q59 : 2003–Q10

[www.CasperYC.club/ukmtnav](http://www.CasperYC.club/ukmtnav)

10. On 2 July 2002, Steve Fossett completed the first solo balloon circumnavigation of the world after  $13\frac{1}{2}$  days. Assuming the balloon travelled along a circle of diameter 12 750 km, roughly what was the average speed of the balloon in km/h?

- A 12      B 40      C 75      D 120      E 300

Q60 : 2005–Q2

[www.CasperYC.club/ukmtnav](http://www.CasperYC.club/ukmtnav)

The number 2005 is the sum of a sequence of five consecutive positive integers. Which of the following numbers occurs in this sequence?

- A 395      B 400      C 405      D 410      E 415

Q61 : 2007–Q10

[www.CasperYC.club/ukmtnav](http://www.CasperYC.club/ukmtnav)

In 1954, a total of 6 527 mm of rain fell at Sprinkling Tarn and this set a UK record for annual rainfall. The tarn has a surface area of 23 450 m<sup>2</sup>. Roughly how many million litres of water fell on Sprinkling Tarn in 1954?

- A 15      B 150      C 1 500      D 15 000      E 150 000

Q62 : 2007–Q8

[www.CasperYC.club/ukmtnav](http://www.CasperYC.club/ukmtnav)

Travelling at an average speed of 100 km/hr, a train took 3 hours to travel to Birmingham. Unfortunately the train then waited just outside the station, which reduced the average speed for the whole journey to 90 km/hr. For how many minutes was the train waiting?

- A 1      B 5      C 10      D 15      E 20

Q63 : 2013–Q10

[www.CasperYC.club/ukmtnav](http://www.CasperYC.club/ukmtnav)

Frank's teacher asks him to write down five integers such that the median is one more than the mean, and the mode is one greater than the median. Frank is also told that the median is 10. What is the smallest possible integer that he could include in his list?

- A 3      B 4      C 5      D 6      E 7

Q64 : 2015–Q5

[www.CasperYC.club/ukmtnav](http://www.CasperYC.club/ukmtnav)

The integer  $n$  is the mean of the three numbers 17, 23 and  $2n$ . What is the sum of the digits of  $n$ ?

- A 4      B 5      C 6      D 7      E 8



Q65 : 2016–Q11

[www.CasperYC.club/ukmtnav](http://www.CasperYC.club/ukmtnav)

In the grid below each of the blank squares and the square marked  $X$  are to be filled by the mean of the two numbers in its adjacent squares. Which number should go in the square marked  $X$ ?

10			$X$		25
----	--	--	-----	--	----

- A 15                      B 16                      C 17                      D 18                      E 19

Q66 : 2017–Q11

[www.CasperYC.club/ukmtnav](http://www.CasperYC.club/ukmtnav)

The teenagers Sam and Jo notice the following facts about their ages:  
 The difference between the squares of their ages is four times the sum of their ages.  
 The sum of their ages is eight times the difference between their ages.  
 What is the age of the older of the two?

- A 15                      B 16                      C 17                      D 18                      E 19

Q67 : 2017–Q2

[www.CasperYC.club/ukmtnav](http://www.CasperYC.club/ukmtnav)

Last year, an earthworm from Wigan named Dave wriggled into the record books as the largest found in the UK. Dave was 40 cm long and had a mass of 26 g.  
 What was Dave's mass per unit length?

- A 0.6 g/cm      B 0.65 g/cm      C 0.75 g/cm      D 1.6 g/cm      E 1.75 g/cm

Q68 : 2018–Q10

[www.CasperYC.club/ukmtnav](http://www.CasperYC.club/ukmtnav)

10. On a training ride, Laura averages speeds of 12 km/h for 5 minutes, then 15 km/h for 10 minutes and finally 18 km/h for 15 minutes.

What was her average speed over the whole ride?

- A 13 km/h              B 14 km/h              C 15 km/h              D 16 km/h              E 17 km/h

Q69 : 2018–Q17

[www.CasperYC.club/ukmtnav](http://www.CasperYC.club/ukmtnav)

17. Bethany has 11 pound coins and some 20p coins and some 50p coins in her purse. The mean value of the coins is 52 pence.

Which could not be the number of coins in the purse?

- A 35                      B 40                      C 50                      D 65                      E 95

Q70 : 2019–Q16

[www.CasperYC.club/ukmtnav](http://www.CasperYC.club/ukmtnav)

16. The numbers  $x$ ,  $y$  and  $z$  satisfy the equations  $9x + 3y - 5z = -4$  and  $5x + 2y - 2z = 13$ .

What is the mean of  $x$ ,  $y$  and  $z$ ?

- A 10                      B 11                      C 12                      D 13                      E 14



Q71 : 2021–Q13

[www.CasperYC.club/ukmtnav](http://www.CasperYC.club/ukmtnav)

13. Which of these is the mean of the other four?

A  $\sqrt{2}$

B  $\sqrt{18}$

C  $\sqrt{200}$

D  $\sqrt{32}$

E  $\sqrt{8}$

Q72 : 2023–Q4

[www.CasperYC.club/ukmtnav](http://www.CasperYC.club/ukmtnav)

In 2016, the world record for completing a 5000m three-legged race was 19 minutes and 6 seconds. It was set by Damian Thacker and Luke Symonds in Sheffield.

What was their approximate average speed in km/h?

A 10

B 12

C 15

D 18

E 25

Q73 : 2024–Q8

[www.CasperYC.club/ukmtnav](http://www.CasperYC.club/ukmtnav)

In the following expressions,  $x$  is non-zero. When one of these expressions is removed, the mean of the remaining four is  $11x$ .

Which expression is removed?

A  $4x$

B  $8x$

C  $12x$

D  $16x$

E  $20x$

## 4 Circles

Q74 : 2004–Q24

[www.CasperYC.club/ukmtnav](http://www.CasperYC.club/ukmtnav)

24. The diagram (not to scale) shows two circles of radius 105 which are tangent to each other and to a circle of radius 14. What is the radius of the largest circle which can be placed in the shaded region?

A 2

B 3

C 4

D 5

E 6

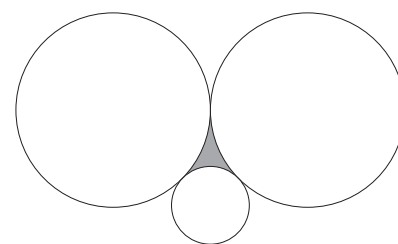

Q75 : 2005–Q11

[www.CasperYC.club/ukmtnav](http://www.CasperYC.club/ukmtnav)

A sculpture is made up of 12 wooden cylinders, each of height 2cm. They are glued together as shown. The diameter of the top cylinder is 2cm and each of the other cylinders has a diameter 2cm more than the one immediately above it. The exhibit stands with its base on a marble table. What, in  $\text{cm}^2$ , is the total surface area of the sculpture, excluding the base?

A  $456\pi$

B  $356\pi$

C  $256\pi$

D  $156\pi$

E  $144\pi$

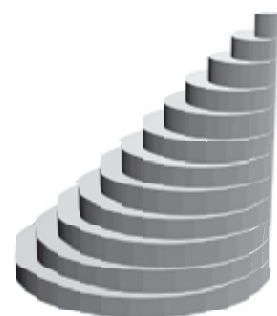

Q76 : 2005–Q23

[www.CasperYC.club/ukmtnav](http://www.CasperYC.club/ukmtnav)

The diagram shows four touching circles, each of which also touches the sides of an equilateral triangle with sides of length 3. What is the area of the shaded region?

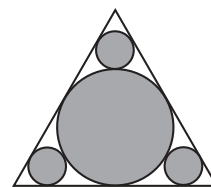

- A  $\frac{11\pi}{12}$     B  $\pi$     C  $\frac{(4 + \sqrt{3})\pi}{6}$     D  $\frac{(3 + \sqrt{3})\pi}{4}$     E  $\frac{37\pi}{36}$

Q77 : 2006–Q23

[www.CasperYC.club/ukmtnav](http://www.CasperYC.club/ukmtnav)

In the diagram, the circle and the two semicircles have radius 1. What is the perimeter of the square?

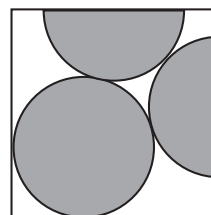

- A  $6 + 4\sqrt{2}$     B  $2 + 4\sqrt{2} + 2\sqrt{3}$     C  $3\sqrt{2} + 4\sqrt{3}$   
D  $4 + 2\sqrt{2} + 2\sqrt{6}$     E 12

Q78 : 2006–Q9

[www.CasperYC.club/ukmtnav](http://www.CasperYC.club/ukmtnav)

The 80 spokes of the giant wheel *The London Eye* are made from 4 miles of cable. Roughly what is the circumference of the wheel in metres?

- A 50    B 100    C 500    D 750    E 900

Q79 : 2007–Q14

[www.CasperYC.club/ukmtnav](http://www.CasperYC.club/ukmtnav)

The point  $O$  is the centre of both circles and the shaded area is one-sixth of the area of the outer circle.

What is the value of  $x$ ?

- A 60    B 64    C 72    D 80    E 84

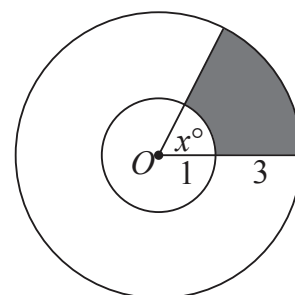

Q80 : 2008–Q14

[www.CasperYC.club/ukmtnav](http://www.CasperYC.club/ukmtnav)

Five touching circles each have radius 1 and their centres are at the vertices of a regular pentagon. What is the radius of the circle through the points of contact  $P$ ,  $Q$ ,  $R$ ,  $S$  and  $T$ ?

- A  $\tan 18^\circ$     B  $\tan 36^\circ$     C  $\tan 45^\circ$     D  $\tan 54^\circ$     E  $\tan 72^\circ$

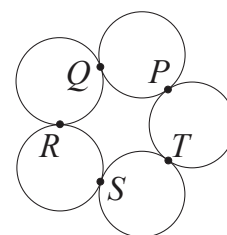

Q81 : 2008–Q18

[www.CasperYC.club/ukmtnav](http://www.CasperYC.club/ukmtnav)

The shaded square of the lattice shown has area 1. What is the area of the circle through the points  $X$ ,  $Y$  and  $Z$ ?

- A  $\frac{9\pi}{2}$       B  $8\pi$       C  $\frac{25\pi}{2}$       D  $25\pi$       E  $50\pi$

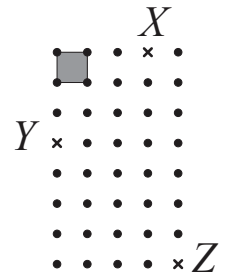

Q82 : 2008–Q20

[www.CasperYC.club/ukmtnav](http://www.CasperYC.club/ukmtnav)

The diagram shows four semicircles symmetrically placed between two circles. The shaded circle has area 4 and each semicircle has area 18. What is the area of the outer circle?

- A  $72\sqrt{2}$       B 100      C 98      D 96      E  $32\sqrt{3}$

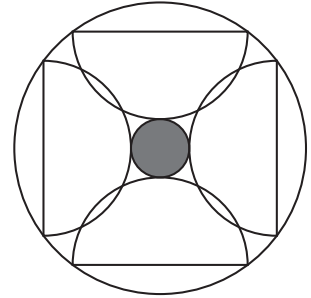

Q83 : 2009–Q21

[www.CasperYC.club/ukmtnav](http://www.CasperYC.club/ukmtnav)

A frustum is the solid obtained by slicing a right-circular cone perpendicular to its axis and removing the small cone above the slice. This leaves a shape with two circular faces and a curved surface. The original cone has base radius 6 cm and height 8 cm, and the curved surface area of the frustum is equal to the area of the two circles. What is the height of the frustum?

- A 3 cm      B 4 cm      C 5 cm      D 6 cm      E 7 cm



Q84 : 2010–Q16

[www.CasperYC.club/ukmtnav](http://www.CasperYC.club/ukmtnav)

$PQRS$  is a quadrilateral inscribed in a circle of which  $PR$  is a diameter. The lengths of  $PQ$ ,  $QR$  and  $RS$  are 60, 25 and 52 respectively. What is the length of  $SP$ ?

- A  $21\frac{2}{3}$       B  $28\frac{11}{13}$       C 33      D 36      E 39

Q85 : 2010–Q23

[www.CasperYC.club/ukmtnav](http://www.CasperYC.club/ukmtnav)

The diagram shows two different semicircles inside a square with sides of length 2. The common centre of the semicircles lies on a diagonal of the square.

What is the total shaded area?

- A  $\pi$       B  $6\pi(3 - 2\sqrt{2})$       C  $\pi\sqrt{2}$       D  $3\pi(2 - \sqrt{2})$       E  $8\pi(2\sqrt{2} - 3)$

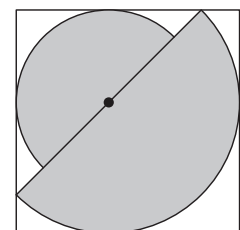

Q86 : 2011–Q24

[www.CasperYC.club/ukmtnav](http://www.CasperYC.club/ukmtnav)

Three circles and the lines  $PQ$  and  $QR$  touch as shown. The distance between the centres of the smallest and the biggest circles is 16 times the radius of the smallest circle. What is the size of  $\angle PQR$ ?

A  $45^\circ$     B  $60^\circ$     C  $75^\circ$     D  $90^\circ$     E  $135^\circ$

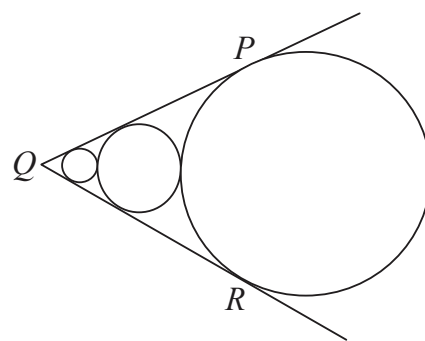

Q87 : 2012–Q11

[www.CasperYC.club/ukmtnav](http://www.CasperYC.club/ukmtnav)

Coco is making clown hats from a circular piece of cardboard. The circumference of the base of each hat equals its slant height, which in turn is equal to the radius of the piece of cardboard. What is the maximum number of hats that Coco can make from the piece of cardboard?

A 3    B 4    C 5    D 6    E 7

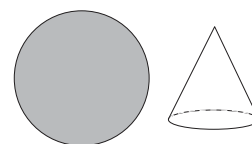

Q88 : 2012–Q17

[www.CasperYC.club/ukmtnav](http://www.CasperYC.club/ukmtnav)

The diagram shows a pattern found on a floor tile in the cathedral in Spoleto, Umbria. A circle of radius 1 surrounds four quarter circles, also of radius 1, which enclose a square. The pattern has four axes of symmetry. What is the side length of the square?

A  $\frac{1}{\sqrt{2}}$     B  $2 - \sqrt{2}$     C  $\frac{1}{\sqrt{3}}$     D  $\frac{1}{2}$     E  $\sqrt{2} - 1$

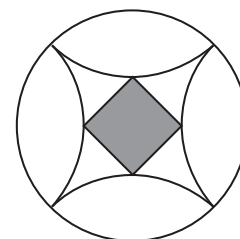

Q89 : 2012–Q20

[www.CasperYC.club/ukmtnav](http://www.CasperYC.club/ukmtnav)

In trapezium  $PQRS$ ,  $SR = PQ = 25\text{cm}$  and  $SP$  is parallel to  $RQ$ . All four sides of  $PQRS$  are tangent to a circle with centre  $C$ . The area of the trapezium is  $600\text{cm}^2$ . What is the radius of the circle?

A 7.5cm    B 8cm    C 9cm    D 10cm    E 12cm

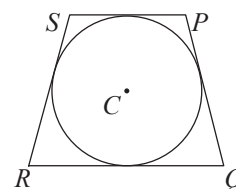

Q90 : 2012–Q22

[www.CasperYC.club/ukmtnav](http://www.CasperYC.club/ukmtnav)

A semicircle of radius  $r$  is drawn with centre  $V$  and diameter  $UW$ . The line  $UW$  is then extended to the point  $X$ , such that  $UW$  and  $WX$  are of equal length. An arc of the circle with centre  $X$  and radius  $4r$  is then drawn so that the line  $XY$  is a tangent to the semicircle at  $Z$ , as shown. What, in terms of  $r$ , is the area of triangle  $YVW$ ?

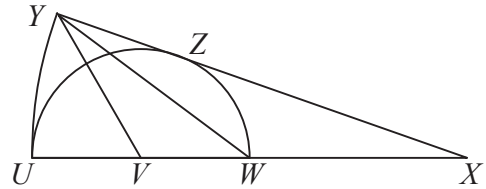

- A  $\frac{4r^2}{9}$       B  $\frac{2r^2}{3}$       C  $r^2$       D  $\frac{4r^2}{3}$       E  $2r^2$

Q91 : 2013–Q11

[www.CasperYC.club/ukmtnav](http://www.CasperYC.club/ukmtnav)

The diagram shows a circle with centre  $O$  and a triangle  $OPQ$ . Side  $PQ$  is a tangent to the circle. The area of the circle is equal to the area of the triangle. What is the ratio of the length of  $PQ$  to the circumference of the circle?

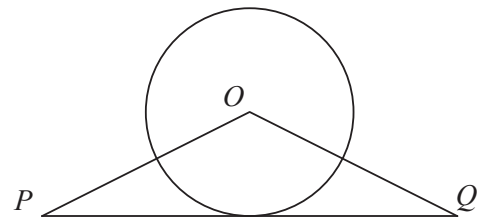

- A 1 : 1      B 2 : 3      C 2 :  $\pi$       D 3 : 2      E  $\pi$  : 2

Q92 : 2013–Q21

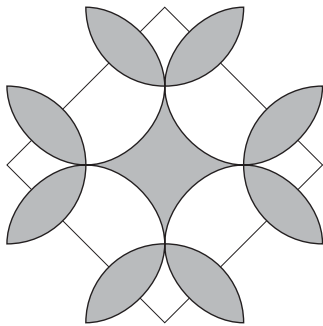
[www.CasperYC.club/ukmtnav](http://www.CasperYC.club/ukmtnav)

The shaded design shown in the diagram is made by drawing eight circular arcs, all with the same radius. The centres of four arcs are the vertices of the square; the centres of the four touching arcs are the midpoints of the sides of the square. The diagonals of the square have length 1.

What is the total length of the border of the shaded design?

- A  $2\pi$       B  $\frac{5\pi}{2}$       C  $3\pi$       D  $\frac{7\pi}{2}$       E  $4\pi$

Q93 : 2014–Q16

[www.CasperYC.club/ukmtnav](http://www.CasperYC.club/ukmtnav)

The diagram shows a rectangle measuring  $6 \times 12$  and a circle. The two shorter sides of the rectangle are tangents to the circle. The circle and rectangle have the same centre. The region that lies inside both the rectangle and the circle is shaded. What is its area?

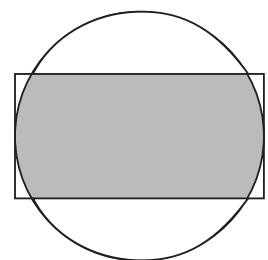

- A  $12\pi + 18\sqrt{3}$       B  $24\pi - 3\sqrt{3}$       C  $18\pi - 8\sqrt{3}$   
D  $18\pi + 12\sqrt{3}$       E  $24\pi + 18\sqrt{3}$

